

## FN 50

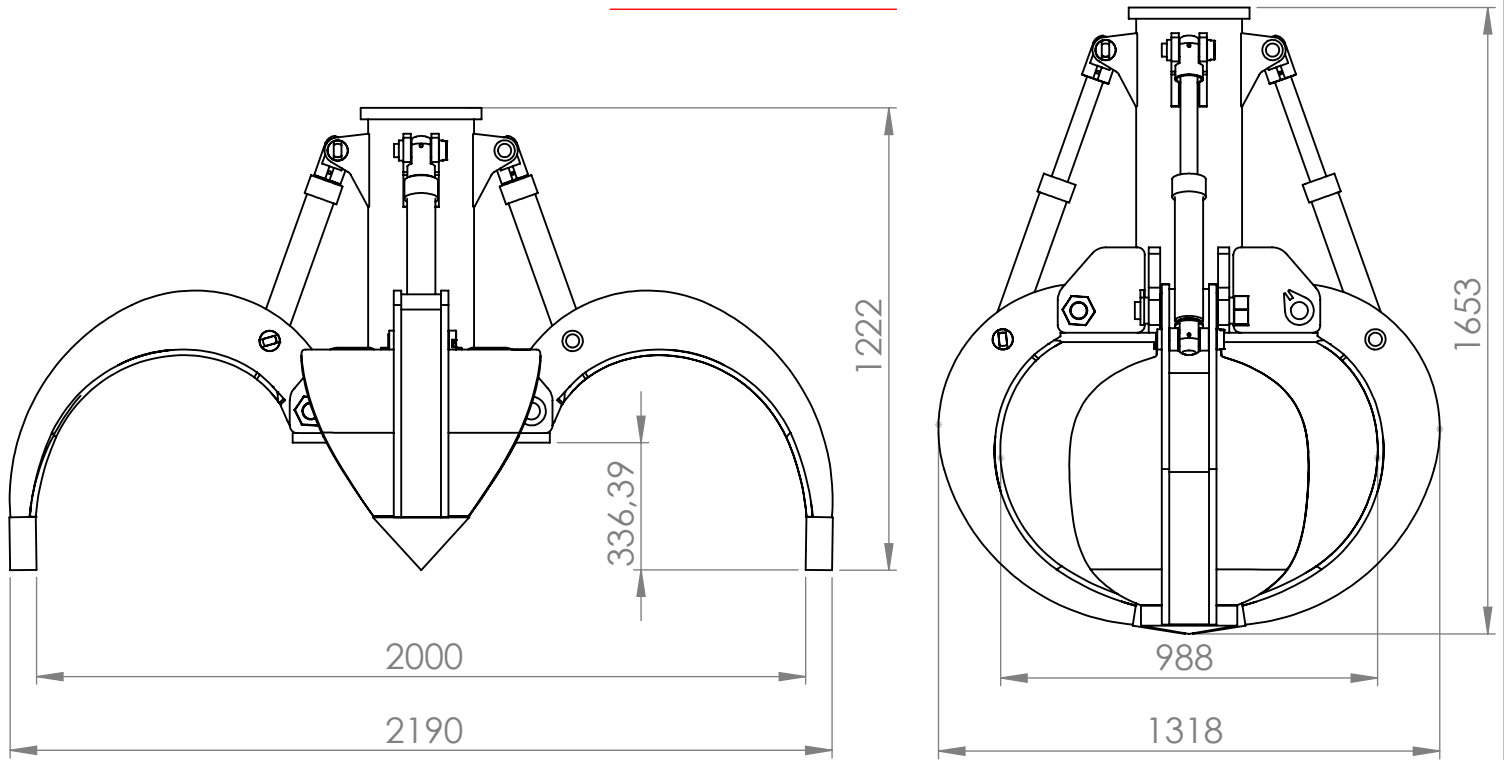

CAPACIDAD/ CAPACITY	PRESIÓN DE TRABAJO/WORKING PRESSURE	NÚMERO DE PALAS/NUMBER OF CLAWS	PESO/ WEIGHT (KG)	FUERZA DE CIERRE/TIGHTENING FORCE
400 L	350 BAR	4/5	931/4 1120/5	1400 KG

**SE PUEDEN ADAPTAR LOS SIGUIENTES GIROS:  
 CAN ADAPT THE FOLLOWING TURNS:**

### IR 10

